

Grooved Type Butterfly Valve

Model No. : NIBO-G300

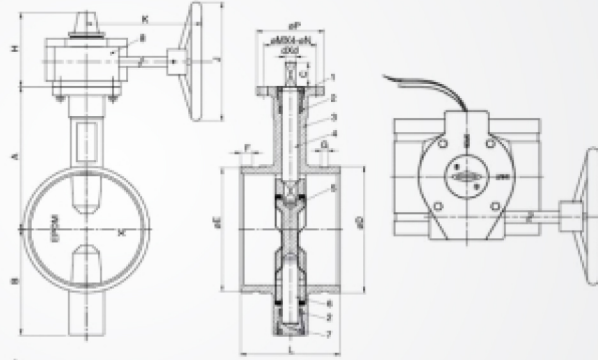

Assembly Diagram



Carried Standard

Design Standard : Ap1609

Face To Face Standard : ASME B16.1

Top Standard : ISO 6211

Test Standard : AP1598

ITEM/SIZE	A	B	C	D	E	F	G	H	K	J	P	M	N	D	L
2-1/2"	125	95	32	76.1	72.1	15.9	7.9	111	218	152	90	70	9	10	96.4
3"	140	100	32	88.9	84.9	15.9	7.9	111	218	152	90	70	9	11	97
4"	160	100	32	114.3	110.1	15.9	9.5	111	218	152	90	70	9	14	115.1
5"	170	125	32	168.3	137	15.9	9.5	111	218	152	90	70	9	14	132.4
6"	190	140	32	219.1	164	15.9	9.5	111	218	152	90	70	9	16	132.4
8"	230	175	32	273	214.6	19	11.1	126	232	300	125	102	12	19	147.4
10"	260	200	45	324	268.3	19	12.7	126	232	300	125	102	12	22	159
12"	300	240	45	375	318.3	19	12.7	161	252	300	125	102	14	24	165

No	Name	Material
1	End Face Seal	EPDM
2	Lower Shaft Sealing Nut	WCB
3	Lower Shaft	SS416
4	Disc	DI+EPDM
5	Upper Shaft	SS416
6	Body	DI
7	Shaft Seal	EPDM
8	Upper Shaft Sealing Nut	WCB

Specification

Size: 2 1/2" Through 12"

W.P: 300 PSI (20 Bars)

Max T.P: 600 PSI (40 Bars)

W.T.P: 250° F (120° C)

Approval: UL listed & FM Approved

Note: from Size : 2 1/2" to 8 " UL listed & FM Approved And Size:10" & 12" UL listed only.