

1078G Butterfly Valve (Wafer Type), PN 2.5 with S.G Iron Disc

Salient Features

- Design Standard IS 13095 / BS EN 593 (BS 5155).
- Wafer Type.
- Lever Operated.
- S.G Iron construction.
- S.G Iron disc which is accurately guided between the two stems.
- Integrally moulded rubber lining (EPDM / Nitrile / Neoprene* / Viton* / Silicon*) as per requirement which provides seating to the valve disc, as a primary seal to the stem and gasket joint with matching pipe flanges.
- Two Piece Stem design which is precisely guided between the PTFE / Bronze bushes.
- Compatible to sandwich between flanges as per BS 10 Table D, E, F,H, DIN, PN 10, PN 16, PN 25, PN 40, ASA 150, ASA 300, IS 778, IS 6392 Table 17 and IS 1538.



*Valves with Neoprene / Viton / Silicon lining can also be provided at nominal extra cost.

PN 2.5 -
Test Pressure (Hydrostatic) :
Shell : 3.75 MPa
Seat : 2.75 MPa
Maximum Working Pressure : 2.5 MPa
Maximum Working Temperature : 90°C

Suitable For
Water

Materials

P.No.	Name of Part	Material of Construction	Specification	Qty.
1	Flow Control Lever	Carbon Steel (Powder Coated)	---	1
2	Notch Plate	Carbon Steel (Powder Coated)	---	1
3	Packing Bush	PTFE	---	1
4	Upper Stem	Stainless Steel	IS 6603 Gr. 12 Cr12	1
5	Body	S.G Iron	IS 1865 Gr. 400/15	1
6	Disc	S.G Iron (Epoxy Coated)	IS 1865 Gr. 400/15	1
7	Taper Pin (Optional)	Stainless Steel	IS 6603 Gr. 12 Cr12	1
8	Bush	Bronze	IS 318 Gr. LTB 2	1
9	Lower Stem	Stainless Steel	IS 6603 Gr. 12 Cr12	1
10	'O' Ring	Nitrile Rubber	IS 5192 - 1	1
11	L - Key Screw	Carbon Steel	---	1
12	C - Sunk Screw & Nuts	Carbon Steel	---	2 Each
13	Locking Washer	Spring Steel	---	2
14	Boby Lining	EPDM / Nitrile	IS 5192 - 1	1
15	Name Plate	Aluminium	---	1

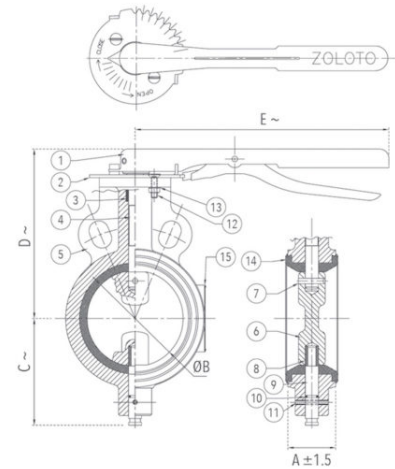

Sizes / Dimensions

Size (Inches)	Size (mm)	A ±1.5	ØB	C ~	D ~	E ~
1 1/2	40	33	40.6	57	113	260
2	50	43	53	73	125	260
2 1/2	65	46	67.5	80	140	260
3	80	46	81.3	88	145	260
4	100	52	101.5	110	178	260
5	125	56	127.1	122	190	260
6	150	56	151.5	151	204	260

~ ±10

NOTE : Valves upto 150mm can also be provided with limit switch and gear arrangement at nominal extra cost.